



July 3, 2014

BROWN-WILBERT INCORPORATED
BROWN PRECAST
CONNER BROWN
2280 N. HAMLINE AVENUE
ROSEVILLE MN 55113

Re: Description: SEWAGE TANKS, CONCRETE
Manufacturer: BROWN-WILBERT INCORPORATED
Product Name: SEPTIC/SEPTIC, SEPTIC/PUMP, SEPTIC/SIPHON OR HOLDING
Model Number(s): 1600-2C, 1600-2C-R AND 1600-2C-L
(43" L.L., 23.37/14.05 GAL/IN., 84 IN. MAX. DEPTH OF BURY, 771 G.P.D. WHEN USED
AS A SEPTIC/SEPTIC TANK OR 481 G.P.D. WHEN USED AS A SEPTIC/PUMP OR
SEPTIC/SIPHON TANK BASED ON A 3 YR. SERVICE INTERVAL FOR RESIDENTIAL
WASTEWATER; TANK DIMENSIONS (OD) = 156 IN. L X 68 IN. W X 61 IN. H)
Product File No: 20140125

The specifications and/or plans for this plumbing product have been reviewed and determined to be in compliance with chapters SPS 382 through 384, Wisconsin Administrative Code, and Chapters 145 and 160, Wisconsin Statutes.

The Department hereby issues an approval based on the Wisconsin Statutes and the Wisconsin Administrative Code. **This approval is valid until the end of July 2019.**

This approval is contingent upon compliance with the following stipulation(s):

- This tank must be designed to withstand the pressures to which it will be subjected.
- The manufacturer must keep at the manufacturing plant a set of plans and specifications bearing the department's stamp of approval. The plans and specifications must be open to inspection by an authorized representative of the department.
- When this product has an effluent filter installed in an interior wall, the space between the top of the interior wall and bottom of the tank's cover must be sealed with a material that will withstand the environment in the tank and in a manner that will prevent waste from passing over the interior wall.
- When this product receives wastewater from dwellings and is used as a septic tank, it will produce an effluent quality with a maximum monthly average value for BOD5 greater than 30 mg/L but less than or equal to 220 mg/L, TSS greater than 30 mg/L but less than or equal to 150 mg/L and F.O.G. less than or equal to 30 mg/L.
- This product is approved to use the following:
 - Four or six-inch inlet and outlet openings.
 - Side pipe openings for siphon, pump and holding tanks.
 - Dual four-inch inlets and/or outlets.
 - Four-inch discharge opening in riser.
 - Two or three-inch Schedule 40 PVC cast in riser for electrical wiring.
 - Plastic access risers manufactured by IPEX, JM Eagle, or Prinsco.
 - Osseo Plastic and Supply, Inc. baffles.

- **BEDDING:** Proper use of bedding materials is important to ensure service life of the tank structure. Bedding must be capable of bearing the weight of the tank. Bedding material shall have the ability of 100% to be able to pass through a 3/4-inch screen. Bedding thickness shall be 4 inch minimum compacted (thickness may vary with existing conditions).
- **BACKFILL:** Sidewalls of tanks require dry backfill materials that have the ability of 100% to be able to pass through a 2-inch screen and have a minimum of 12 inches on all sides from bottom to top of tank. Backfill material shall be placed in a manner to avoid impact loads on the sidewall of the tank.

The department is in no way endorsing this product or any advertising, and is not responsible for any situation which may result from its use.

Sincerely,



Glen Jones, M.S.
POWTS Product Reviewer
phone: (608) 267-5265
fax: (608) 267-9723
email: glen.jones@wi.gov

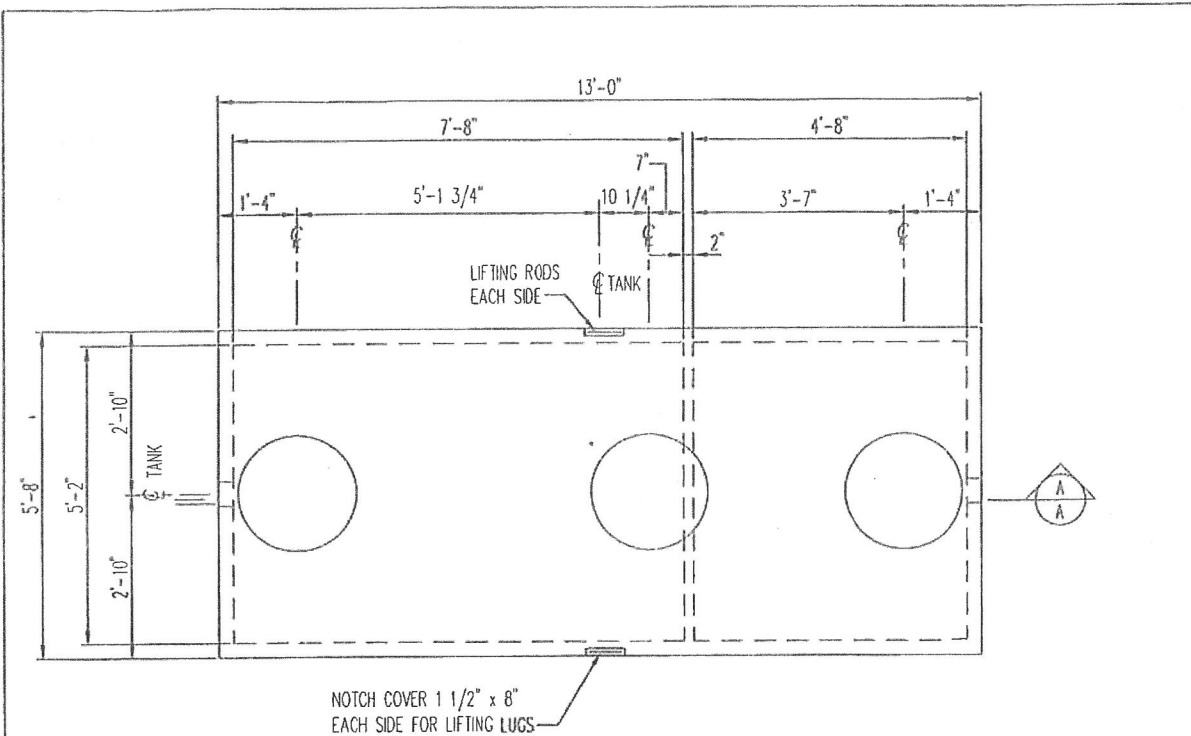

1600 GALLON 2 COMP. TANK
 1/2" = 1'-0"

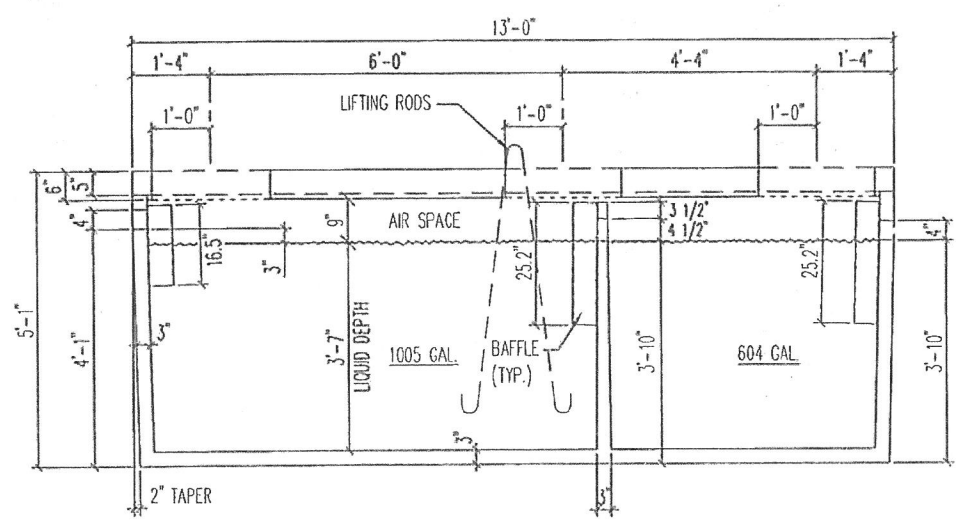

SECTION
 1/2" = 1'-0"

NOTE:
 1. PROVIDE MINIMUM 1" CLEAR BETWEEN TOP OF BAFFLE AND UNDERSIDE OF LID

Conditionally APPROVED
Mr. Jones
 SEE CORRESPONDENCE

RECEIVED
 APR 16 2014
 SAFETY & BUILDINGS

1600 GALLON 2 COMP.
 SEPTIC TANK
 (1600 2C)

Brown Wilbert

WEIGHT=14,500#
 MAX. SOIL COVER= 7'-0"
 TOTAL LIQUID VOLUME= 1609 GAL.

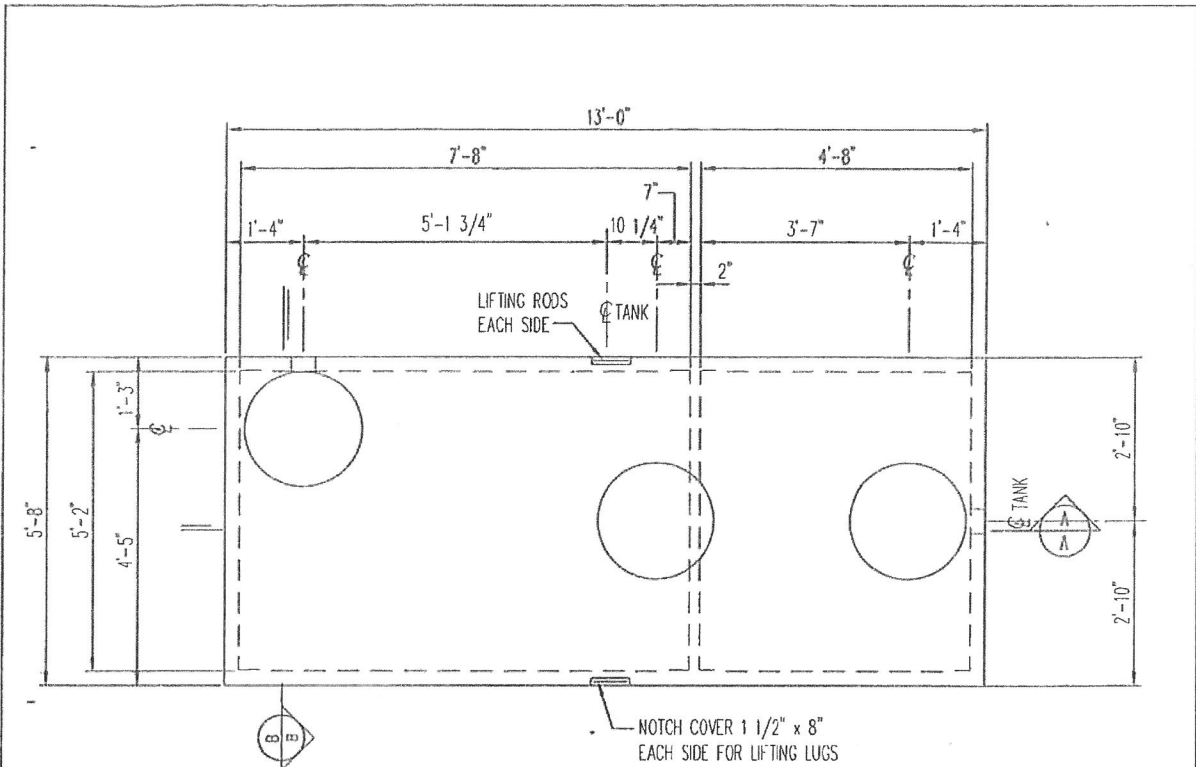

1600 GALLON 2 COMP. TANK
 1/2" = 1'-0"

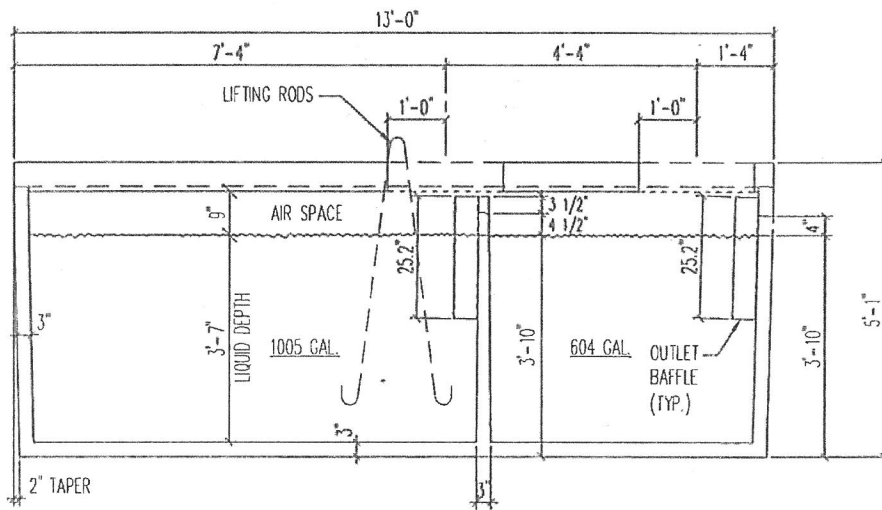

SECTION
 1/2" = 1'-0"

NOTE:
 1. PROVIDE MINIMUM 1" CLEAR BETWEEN TOP OF BAFFLE AND UNDERSIDE OF LID

Conditionally
APPROVED

M. Jones
 SEE CORRESPONDENCE

RECEIVED

APR 16 2014

SAFETY & BUR. APP.

1600 GALLON 2 COMP.
 SEPTIC TANK
 (1600 2C-L)

Brown Wilbert

WEIGHT=14,500#
 MAX. SOIL COVER= 7'-0"
 TOTAL LIQUID VOLUME= 1609 GAL.

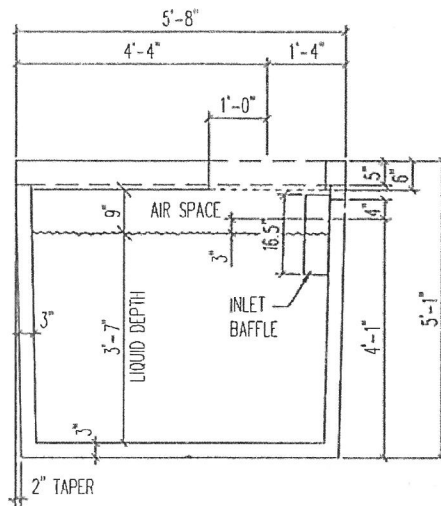

SECTION
 $\frac{1}{2}'' = 1'-0''$

Conditionally
APPROVED

[Signature]
 SEE CORRESPONDENCE

NOTE:
 1. PROVIDE MINIMUM 1" CLEAR BETWEEN TOP OF BAFFLE AND UNDERSIDE OF LID.

RECEIVED

APR 16 2014

SAFETY & BUILDINGS

1600 GALLON 2 COMP.
 SEPTIC TANK
 (1600 2C-R)

Brown Wilbert

WEIGHT=14,500#
 MAX. SOIL COVER= 7'-0"
 TOTAL LIQUID VOLUME= 1609 GAL.