

# **BrownPrecast**

a division of Brown-Wilbert, Inc.



**INFILTRATOR®**  
water technologies

## **Product Reference Guide**



**INFILTRATOR®**  
water technologies



# The Quick4® Plus Standard Low Profile (LP) Chamber

## Quick4 Plus™ Series

The Quick4 Plus Standard Low Profile (LP) offers maximum strength through its four center structural columns. This chamber can be installed in a 36-inch-wide trench. It is shorter in height than Infiltrator's other Standard model chambers, allowing for shallower installation. Like the original line of Quick4 chambers, it offers advanced contouring capability with its Contour Swivel Connection™, which permits turns up to 15°, right or left. The Quick4 Plus All-in-One 8 and Quick4 Plus Endcaps provide increased flexibility in system design and configurations.



**Maximum Strength**

### Quick4 Plus Standard LP Chamber Specifications

<b>Size</b>	34"W x 53"L x 8"H (864 mm x 1346 mm x 203 mm)
<b>Effective Length</b>	48" (1219 mm)
<b>Louver Height</b>	6.3" (160 mm)
<b>Storage Capacity</b>	32 gal (121 L)
<b>Invert Height</b>	3.3" (84 mm), 9.6" (244 mm)



### Quick4 Plus Standard Low Profile (LP) Chamber Benefits:

- Low profile design makes this chamber ideal for shallow applications
- Reduces imported fill needed for cap and fill systems
- Four center structural columns offer superior strength
- Advanced contouring connections
- Latching mechanism allows for quick installation
- Four-foot chamber lengths are easy to handle and install
- Supports wheel loads of 16,000 lbs/axle with 12" of cover

### Quick4 Plus All-in-One Periscope Benefits:

- Allows for raised invert installations
- 180° directional inletting
- 12" raised invert is ideal for serial applications



### Quick4 Plus All-in-One 8 Endcap Benefits:

- May be used at the end of chamber row for an inlet/outlet or can be installed mid-trench
- Mid-trench connection feature allows center feed inletting of chamber rows
- Center-feed connection allows for easy installation of serial distribution systems
- Variable pipe connection options allow for side, end or top inletting
- Piping drill points are set for gravity or pressure pipe

### Quick4 Plus Endcap Benefits:

- Simple, flat design
- Allows installation of a pipe from the end only
- Piping drill points are set for gravity or pressure pipe



Certified by the International Association of Plumbing and Mechanical Officials (IAPMO)



APPROVED in \_\_\_\_\_

**Quick4 Plus Standard Low Profile Chamber**

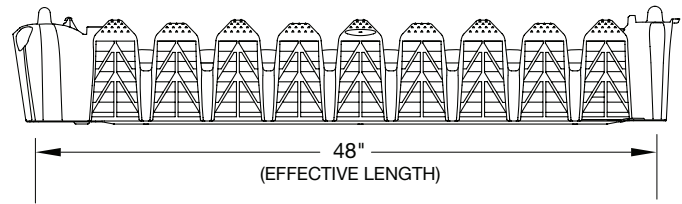
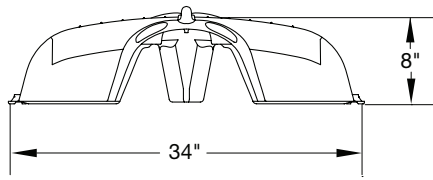

**Quick4 Plus All-in-One 8 Endcap**

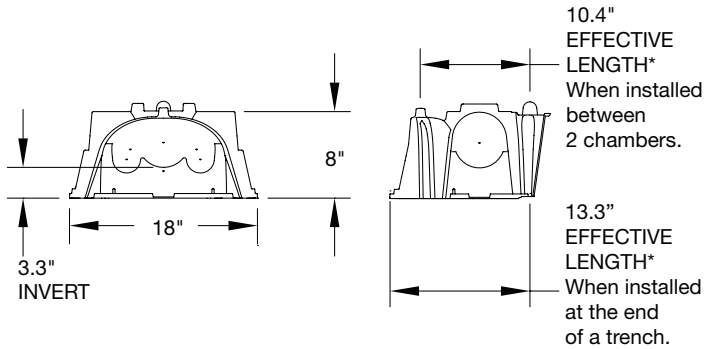

**Quick4 Plus Endcap**

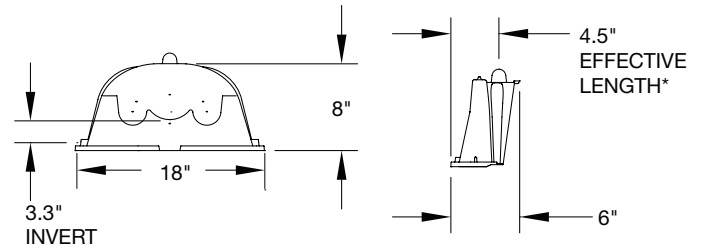

**Quick4 Plus All-in-One Periscope**

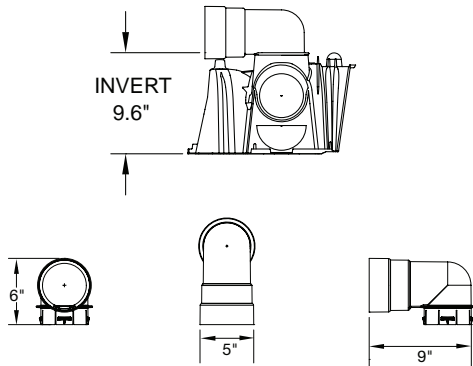

**INFILTRATOR WATER TECHNOLOGIES STANDARD LIMITED WARRANTY**

(a) The structural integrity of each chamber, endcap and other accessory manufactured by Infiltrator ("Units"), when installed and operated in a leachfield of an onsite septic system in accordance with Infiltrator's instructions, is warranted to the original purchaser ("Holder") against defective materials and workmanship for one year from the date that the septic permit is issued for the septic system containing the Units; provided, however, that if a septic permit is not required by applicable law, the warranty period will begin upon the date that installation of the septic system commences. To exercise its warranty rights, Holder must notify Infiltrator in writing at its Corporate Headquarters in Old Saybrook, Connecticut within fifteen (15) days of the alleged defect. Infiltrator will supply replacement Units for Units determined by Infiltrator to be covered by this Limited Warranty. Infiltrator's liability specifically excludes the cost of removal and/or installation of the Units.

(b) THE LIMITED WARRANTY AND REMEDIES IN SUBPARAGRAPH (a) ARE EXCLUSIVE. THERE ARE NO OTHER WARRANTIES WITH RESPECT TO THE UNITS, INCLUDING NO IMPLIED WARRANTIES OF MERCHANTABILITY OR FITNESS FOR A PARTICULAR PURPOSE

(c) This Limited Warranty shall be void if any part of the chamber system is manufactured by anyone other than Infiltrator. The Limited Warranty does not extend to incidental, consequential, special or indirect damages. Infiltrator shall not be liable for penalties or liquidated damages, including loss of production and profits, labor and materials, overhead costs, or other losses or expenses incurred by the Holder or any third party. Specifically excluded from Limited Warranty coverage are damage to the Units due to ordinary wear and tear, alteration, accident, misuse, abuse or neglect of the Units; the Units being subjected to vehicle traffic or other conditions which are not permitted by the installation instructions; failure to maintain the minimum ground covers set forth in the installation instructions; the placement of improper materials into the system containing the Units; failure of the Units or the septic system due to improper siting or improper sizing, excessive water usage, improper grease disposal, or improper operation; or any other event not caused by Infiltrator. This Limited Warranty shall be void if the Holder fails to comply with all of the terms set forth in this Limited Warranty. Further, in no event shall Infiltrator be responsible for any loss or damage to the Holder, the Units, or any third party resulting from installation or shipment, or from any product liability claims of Holder or any third party. For this Limited Warranty to apply, the Units must be installed in accordance with all site conditions required by state and local codes; all other applicable laws; and Infiltrator's installation instructions.

(d) No representative of Infiltrator has the authority to change or extend this Limited Warranty. No warranty applies to any party other than the original Holder.

The above represents the Standard Limited Warranty offered by Infiltrator. A limited number of states and counties have different warranty requirements. Any purchaser of Units should contact Infiltrator's Corporate Headquarters in Old Saybrook, Connecticut, prior to such purchase, to obtain a copy of the applicable warranty, and should carefully read that warranty prior to the purchase of Units.



4 Business Park Road  
P.O. Box 768  
Old Saybrook, CT 06475  
860-577-7000 • Fax 860-577-7001  
**1-800-221-4436**  
[www.infiltratorwater.com](http://www.infiltratorwater.com)

U.S. Patents: 4,759,661; 5,017,041; 5,156,488; 5,336,017; 5,401,116; 5,401,459; 5,511,903; 5,716,163; 5,588,778; 5,839,844 Canadian Patents: 1,329,959; 2,004,564 Other patents pending. Infiltrator, Equalizer, Quick4, and SideWinder are registered trademarks of Infiltrator Water Technologies. Infiltrator is a registered trademark in France. Infiltrator Water Technologies is a registered trademark in Mexico. Contour, MicroLeaching, PolyTuff, ChamberSpacer, MultiPort, PosiLock, QuickCut, QuickPlay, SnapLock and StraightLock are trademarks of Infiltrator Water Technologies. PolyLok is a trademark of PolyLok, Inc. TUF-TITE is a registered trademark of TUF-TITE, INC. Ultra-Rib is a trademark of IPEX Inc.



**INFILTRATOR®**  
water technologies



## The Quick4® Plus Standard Chamber

### Quick4 Plus™ Series

The Quick4 Plus Standard Chamber offers maximum strength through its two center structural columns. This chamber can be installed in a 36-inch-wide trench. Like the original line of Quick4 chambers, it offers advanced contouring capability with its Contour Swivel Connection™ which permits turns up to 15-degrees, right or left. It is also available in four-foot lengths to provide optimal installation flexibility. The Quick4 Plus All-in-One 12 Endcap, and the Quick4 Periscope are available with this chamber, providing increased flexibility in system configurations.



**Maximum Strength**

### Quick4 Plus Standard Chamber Specifications

**Size**

34"W x 53"L x 12"H  
(864 mm x 1346 mm x 305 mm)

**Effective Length**

48" (1219 mm)

**Louver Height**

8" (203 mm)

**Storage Capacity**

47 gal (178 L)

**Invert Height**

0.6" (15 mm), 5.3" (135 mm),  
8.0" (203 mm), 12.7" (323 mm)

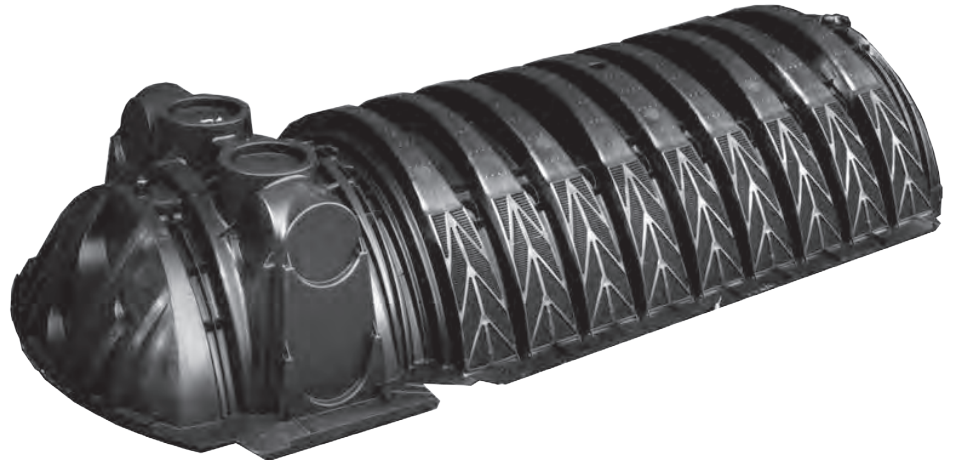

### Quick4 Plus Standard Chamber Benefits:

- Two center structural columns offer increased stability and superior strength
- Advanced contouring connections
- Latching mechanism allows for quick installation
- Four-foot chamber lengths are easy to handle and install
- Supports wheel loads of 16,000 lbs/axle with 12" of cover



### Quick4 Plus All-in-One 12 Endcap Benefits:

- May be used at the end of chamber row for an inlet/outlet or can be installed mid-trench
- Mid-trench connection feature allows construction of chamber rows with center feed, as an alternative to inletting at the ends of chamber rows
- Center-feed connection allows for easy installation of serial distribution systems
- Pipe connection options include sides, ends or top



### Quick4 Plus All-in-One Periscope Benefits:

- Allows for raised invert installations
- 180° directional inletting
- 12" raised invert is ideal for serial applications

APPROVED in \_\_\_\_\_

Certified by the International Association of Plumbing and Mechanical Officials (IAPMO)



**Quick4 Plus Standard Chamber**

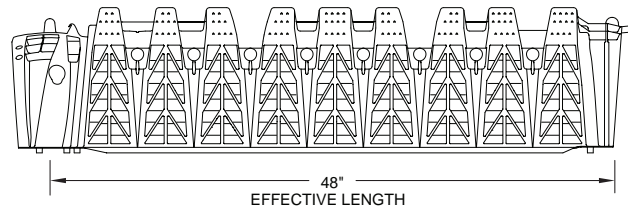
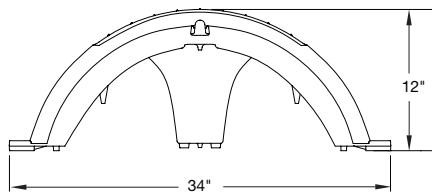

**Quick4 Plus All-in-One 12 Endcap**

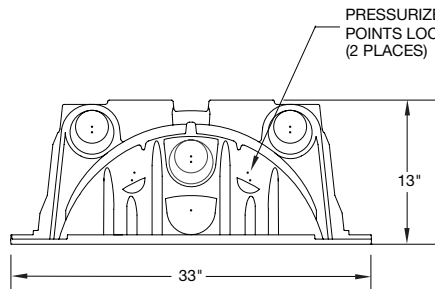

FRONT VIEW

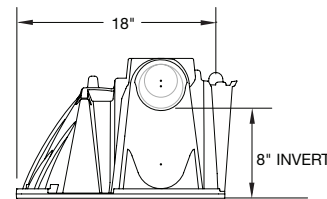

SIDE VIEW

**Quick4 Plus All-in-One Periscope**

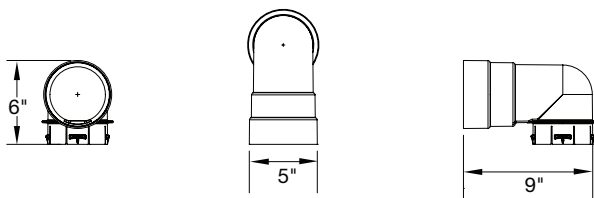
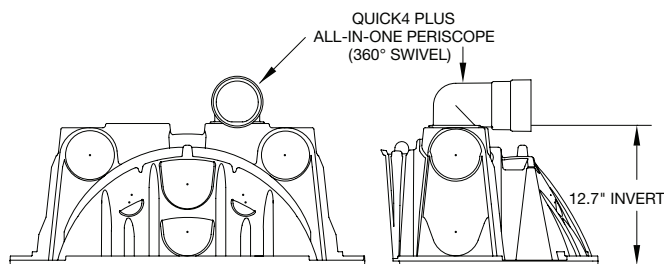

**INFILTRATOR WATER TECHNOLOGIES STANDARD LIMITED WARRANTY**

(a) The structural integrity of each chamber, endcap and other accessory manufactured by Infiltrator ("Units"), when installed and operated in a leachfield of an onsite septic system in accordance with Infiltrator's instructions, is warranted to the original purchaser ("Holder") against defective materials and workmanship for one year from the date that the septic permit is issued for the septic system containing the Units; provided, however, that if a septic permit is not required by applicable law, the warranty period will begin upon the date that installation of the septic system commences. To exercise its warranty rights, Holder must notify Infiltrator in writing at its Corporate Headquarters in Old Saybrook, Connecticut within fifteen (15) days of the alleged defect. Infiltrator will supply replacement Units for Units determined by Infiltrator to be covered by this Limited Warranty. Infiltrator's liability specifically excludes the cost of removal and/or installation of the Units.

(b) THE LIMITED WARRANTY AND REMEDIES IN SUBPARAGRAPH (a) ARE EXCLUSIVE. THERE ARE NO OTHER WARRANTIES WITH RESPECT TO THE UNITS, INCLUDING NO IMPLIED WARRANTIES OF MERCHANTABILITY OR FITNESS FOR A PARTICULAR PURPOSE

(c) This Limited Warranty shall be void if any part of the chamber system is manufactured by anyone other than Infiltrator. The Limited Warranty does not extend to incidental, consequential, special or indirect damages. Infiltrator shall not be liable for penalties or liquidated damages, including loss of production and profits, labor and materials, overhead costs, or other losses or expenses incurred by the Holder or any third party. Specifically excluded from Limited Warranty coverage are damage to the Units due to ordinary wear and tear, alteration, accident, misuse, abuse or neglect of the Units; the Units being subjected to vehicle traffic or other conditions which are not permitted by the installation instructions; failure to maintain the minimum ground covers set forth in the installation instructions; the placement of improper materials into the system containing the Units; failure of the Units or the septic system due to improper siting or improper sizing, excessive water usage, improper grease disposal, or improper operation; or any other event not caused by Infiltrator. This Limited Warranty shall be void if the Holder fails to comply with all of the terms set forth in this Limited Warranty. Further, in no event shall Infiltrator be responsible for any loss or damage to the Holder, the Units, or any third party resulting from installation or shipment, or from any product liability claims of Holder or any third party. For this Limited Warranty to apply, the Units must be installed in accordance with all site conditions required by state and local codes; all other applicable laws; and Infiltrator's installation instructions.

(d) No representative of Infiltrator has the authority to change or extend this Limited Warranty. No warranty applies to any party other than the original Holder.

The above represents the Standard Limited Warranty offered by Infiltrator. A limited number of states and counties have different warranty requirements. Any purchaser of Units should contact Infiltrator's Corporate Headquarters in Old Saybrook, Connecticut, prior to such purchase, to obtain a copy of the applicable warranty, and should carefully read that warranty prior to the purchase of Units.



4 Business Park Road  
P.O. Box 768  
Old Saybrook, CT 06475  
860-577-7000 • Fax 860-577-7001  
**1-800-221-4436**  
[www.infiltratorwater.com](http://www.infiltratorwater.com)

U.S. Patents: 4,759,661; 5,017,041; 5,156,488; 5,336,017; 5,401,116; 5,401,459; 5,511,903; 5,716,163; 5,588,778; 5,839,844 Canadian Patents: 1,329,959; 2,004,564 Other patents pending. Infiltrator, Equalizer, Quick4, and SideWinder are registered trademarks of Infiltrator Water Technologies. Infiltrator is a registered trademark in France. Infiltrator Water Technologies is a registered trademark in Mexico. Contour, MicroLeaching, PolyTuff, ChamberSpacer, MultiPort, PosiLock, QuickCut, QuickPlay, SnapLock and StraightLock are trademarks of Infiltrator Water Technologies. PolyLok is a trademark of PolyLok, Inc. TUF-TITE is a registered trademark of TUF-TITE, INC. Ultra-Rib is a trademark of IPEX Inc.

© 2013 Infiltrator Water Technologies, LLC. All rights reserved. Printed in U.S.A.

PLUS05 0713

**Contact Infiltrator Water Technologies' Technical Services Department for assistance at 1-800-221-4436**



**INFILTRATOR®**  
water technologies



## The Quick4® Plus High Capacity Chamber

### Quick4 Plus™ Series

The Quick4 Plus High Capacity Chamber offers maximum strength through its two center structural columns. This chamber can be installed in a 36-inch-wide trench. Like the original line of Quick4 chambers, it offers advanced contouring capability with its Contour Swivel Connection™ which permits turns up to 15-degrees, right or left. It is also available in four-foot lengths to provide optimal installation flexibility. The Quick4 Plus All-in-One 12 Endcap, and the Quick4 Periscope are available with this chamber, providing increased flexibility in system configurations.



**Maximum Strength**

### Quick4 Plus High Capacity Chamber Specifications

**Size**

34"W x 53"L x 14"H  
(864 mm x 1346 mm x 356 mm)

**Effective Length**

48" (1219 mm)

**Louver Height**

12" (305 mm)

**Storage Capacity**

54 gal (204 L)

**Invert Height**

0.8" (20 mm), 5.3" (135 mm),  
8.0" (203 mm), 12.7" (323 mm)



### Quick4 Plus High Capacity Chamber Benefits:

- Two center structural columns offer increased stability and superior strength
- Advanced contouring connections
- Latching mechanism allows for quick installation
- Four-foot chamber lengths are easy to handle and install
- Supports wheel loads of 16,000 lbs/axle with 12" of cover



### Quick4 Plus All-in-One 12 Endcap Benefits:

- May be used at the end of chamber row for an inlet/outlet or can be installed mid-trench
- Mid-trench connection feature allows construction of chamber rows with center feed, as an alternative to inletting at the ends of chamber rows
- Center-feed connection allows for easy installation of serial distribution systems
- Pipe connection options include sides, ends or top



### Quick4 Plus All-in-One Periscope Benefits:

- Allows for raised invert installations
- 180° directional inletting
- 12" raised invert is ideal for serial applications

APPROVED in \_\_\_\_\_

Certified by the International Association of Plumbing and Mechanical Officials (IAPMO)



**Quick4 Plus High Capacity Chamber**

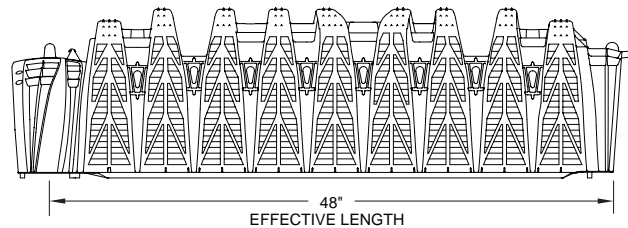
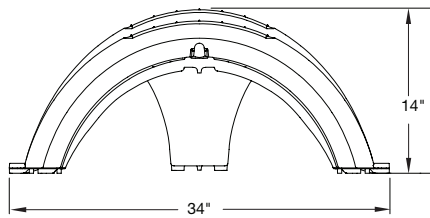

**Quick4 Plus All-in-One 12 Endcap**

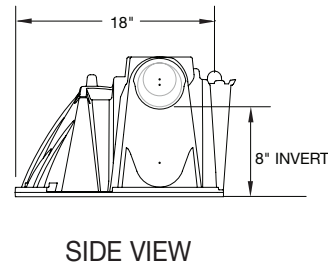
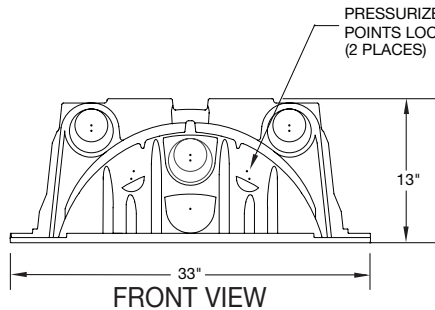

**Quick4 Plus All-in-One Periscope**

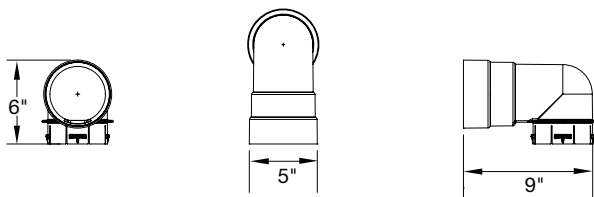
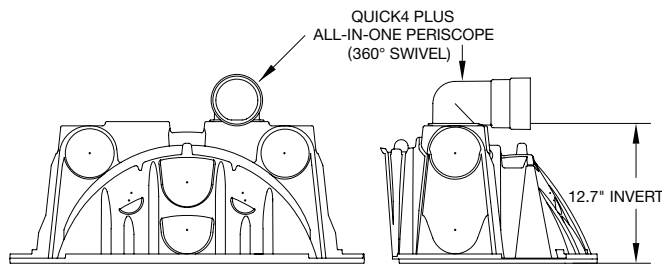

**INFILTRATOR WATER TECHNOLOGIES STANDARD LIMITED WARRANTY**

(a) The structural integrity of each chamber, endcap and other accessory manufactured by Infiltrator ("Units"), when installed and operated in a leachfield of an onsite septic system in accordance with Infiltrator's instructions, is warranted to the original purchaser ("Holder") against defective materials and workmanship for one year from the date that the septic permit is issued for the septic system containing the Units; provided, however, that if a septic permit is not required by applicable law, the warranty period will begin upon the date that installation of the septic system commences. To exercise its warranty rights, Holder must notify Infiltrator in writing at its Corporate Headquarters in Old Saybrook, Connecticut within fifteen (15) days of the alleged defect. Infiltrator will supply replacement Units for Units determined by Infiltrator to be covered by this Limited Warranty. Infiltrator's liability specifically excludes the cost of removal and/or installation of the Units.

(b) THE LIMITED WARRANTY AND REMEDIES IN SUBPARAGRAPH (a) ARE EXCLUSIVE. THERE ARE NO OTHER WARRANTIES WITH RESPECT TO THE UNITS, INCLUDING NO IMPLIED WARRANTIES OF MERCHANTABILITY OR FITNESS FOR A PARTICULAR PURPOSE

(c) This Limited Warranty shall be void if any part of the chamber system is manufactured by anyone other than Infiltrator. The Limited Warranty does not extend to incidental, consequential, special or indirect damages. Infiltrator shall not be liable for penalties or liquidated damages, including loss of production and profits, labor and materials, overhead costs, or other losses or expenses incurred by the Holder or any third party. Specifically excluded from Limited Warranty coverage are damage to the Units due to ordinary wear and tear, alteration, accident, misuse, abuse or neglect of the Units; the Units being subjected to vehicle traffic or other conditions which are not permitted by the installation instructions; failure to maintain the minimum ground covers set forth in the installation instructions; the placement of improper materials into the system containing the Units; failure of the Units or the septic system due to improper siting or improper sizing, excessive water usage, improper grease disposal, or improper operation; or any other event not caused by Infiltrator. This Limited Warranty shall be void if the Holder fails to comply with all of the terms set forth in this Limited Warranty. Further, in no event shall Infiltrator be responsible for any loss or damage to the Holder, the Units, or any third party resulting from installation or shipment, or from any product liability claims of Holder or any third party. For this Limited Warranty to apply, the Units must be installed in accordance with all site conditions required by state and local codes; all other applicable laws; and Infiltrator's installation instructions.

(d) No representative of Infiltrator has the authority to change or extend this Limited Warranty. No warranty applies to any party other than the original Holder.

The above represents the Standard Limited Warranty offered by Infiltrator. A limited number of states and counties have different warranty requirements. Any purchaser of Units should contact Infiltrator's Corporate Headquarters in Old Saybrook, Connecticut, prior to such purchase, to obtain a copy of the applicable warranty, and should carefully read that warranty prior to the purchase of Units.



4 Business Park Road  
P.O. Box 768  
Old Saybrook, CT 06475  
860-577-7000 • Fax 860-577-7001  
**1-800-221-4436**  
[www.infiltratorwater.com](http://www.infiltratorwater.com)

U.S. Patents: 4,759,661; 5,017,041; 5,156,488; 5,336,017; 5,401,116; 5,401,459; 5,511,903; 5,716,163; 5,588,778; 5,839,844 Canadian Patents: 1,329,959; 2,004,564 Other patents pending. Infiltrator, Equalizer, Quick4, and SideWinder are registered trademarks of Infiltrator Water Technologies. Infiltrator is a registered trademark in France. Infiltrator Water Technologies is a registered trademark in Mexico. Contour, MicroLeaching, PolyTuff, ChamberSpacer, MultiPort, PosiLock, QuickCut, QuickPlay, SnapLock and StraightLock are trademarks of Infiltrator Water Technologies. PolyLok is a trademark of PolyLok, Inc. TUF-TITE is a registered trademark of TUF-TITE, INC. Ultra-Rib is a trademark of IPEX Inc.

© 2013 Infiltrator Water Technologies, LLC. All rights reserved. Printed in U.S.A.

PLUS10 0713

**Contact Infiltrator Water Technologies' Technical Services Department for assistance at 1-800-221-4436**

# THE QUICK4® PLUS ALL-IN-ONE PERISCOPE



Quick4 Plus All-in-One Periscope



The Quick4 Plus All-in-One Periscope is inserted into the top of the Quick4 Plus All-in-One Endcap or any Quick4 chamber, allowing for raised invert installations with 180° directional inletting. As a raised invert, it is great for serial applications. This product is compatible with Infiltrator's Quick4 Plus and Quick4 chamber lines.

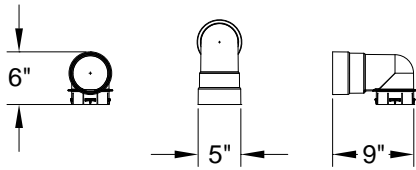

Quick4 Plus All-in-One Periscope

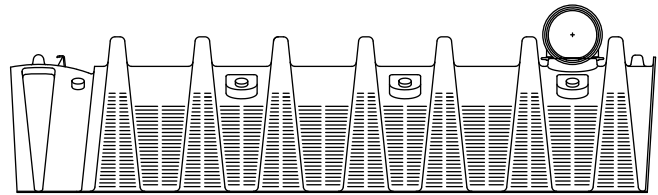

Quick4 chamber with Quick4 Plus All-in-One Periscope

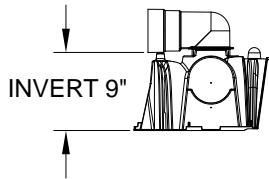

Quick4 Plus All-in-One Endcap with Quick4 Plus All-in-One Periscope

## Quick4 Plus All-in-One Periscope Specifications

Size (W x L x H) ..... 5" x 9" x 6" (12 cm x 23 cm x 15 cm)

Quick4 Plus All-in-One Endcap  
Invert Height .....9" (23 cm)

### INFILTRATOR SYSTEMS, INC. STANDARD LIMITED WARRANTY

(a) The structural integrity of each chamber, end cap and other accessory manufactured by Infiltrator ("Units"), when installed and operated in a leachfield of an onsite septic system in accordance with Infiltrator's instructions, is warranted to the original purchaser ("Holder") against defective materials and workmanship for one year from the date that the septic permit is issued for the septic system containing the Units; provided, however, that if a septic permit is not required by applicable law, the warranty period will begin upon the date that installation of the septic system commences. To exercise its warranty rights, Holder must notify Infiltrator in writing at its Corporate Headquarters in Old Saybrook, Connecticut within fifteen (15) days of the alleged defect. Infiltrator will supply replacement Units for Units determined by Infiltrator to be covered by this Limited Warranty. Infiltrator's liability specifically excludes the cost of removal and/or installation of the Units.

(b) THE LIMITED WARRANTY AND REMEDIES IN SUBPARAGRAPH (a) ARE EXCLUSIVE. THERE ARE NO OTHER WARRANTIES WITH RESPECT TO THE UNITS, INCLUDING NO IMPLIED WARRANTIES OF MERCHANTABILITY OR FITNESS FOR A PARTICULAR PURPOSE

(c) This Limited Warranty shall be void if any part of the chamber system is manufactured by anyone other than Infiltrator. The Limited Warranty does not extend to incidental, consequential, special or indirect damages. Infiltrator shall not be liable for penalties or liquidated damages, including loss of production and profits, labor and materials, overhead costs, or other losses or expenses incurred by the Holder or any third party. Specifically excluded from Limited Warranty coverage are damage to the Units due to ordinary wear and tear, alteration, accident, misuse, abuse or neglect of the Units; the Units being subjected to vehicle traffic or other conditions which are not permitted by the installation instructions; failure to maintain the minimum ground covers set forth in the installation instructions; the placement of improper materials into the system containing the Units; failure of the Units or the septic system due to improper siting or improper sizing, excessive water usage, improper grease disposal, or improper operation; or any other event not caused by Infiltrator. This Limited Warranty shall be void if the Holder fails to comply with all of the terms set forth in this Limited Warranty. Further, in no event shall Infiltrator be responsible for any loss or damage to the Holder, the Units, or any third party resulting from installation or shipment, or from any product liability claims of Holder or any third party. For this Limited Warranty to apply, the Units must be installed in accordance with all site conditions required by state and local codes; all other applicable laws; and Infiltrator's installation instructions.

(d) No representative of Infiltrator has the authority to change or extend this Limited Warranty. No warranty applies to any party other than the original Holder.

The above represents the Standard Limited Warranty offered by Infiltrator. A limited number of states and counties have different warranty requirements. Any purchaser of Units should contact Infiltrator's Corporate Headquarters in Old Saybrook, Connecticut, prior to such purchase, to obtain a copy of the applicable warranty, and should carefully read that warranty prior to the purchase of Units.



**INFILTRATOR®**  
systems inc.

6 Business Park Road • P.O. Box 768  
Old Saybrook, CT 06475  
860.577.7000 • FAX 860.577.7001

800.221.4436

[www.infiltratorsystems.com](http://www.infiltratorsystems.com)





The Infiltrator IM-540 is a lightweight strong and durable septic/pump tank. This watertight tank design is offered with Infiltrator's line of custom-fit risers and heavy-duty lids. Infiltrator injection molded tanks provide a revolutionary improvement in plastic tank design, offering long-term exceptional strength and watertightness.

## Features & Benefits

- Strong injection molded polypropylene construction
- Lightweight plastic construction and inboard lifting lugs allow for easy delivery and handling
- Integral heavy-duty green lids that interconnect with TW™ risers and pipe riser solutions
- Structurally reinforced access ports eliminate distortion during installation and pump-outs
- Reinforced structural ribbing offers additional strength
- Can be installed with 6" to 48" of cover
- Can be pumped dry during pump-outs
- Suitable for use as a pump tank or rainwater (non-potable) tank
- No special installation, backfill or water filling procedures are required

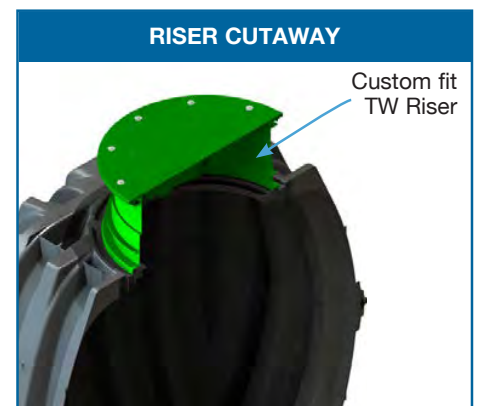
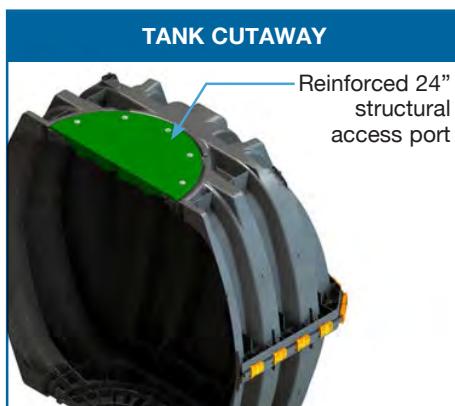

# IM-540 General Specifications and Illustrations

The IM-540 is an injection molded two piece mid-seam plastic tank. The IM-540 injection molded plastic design allows for a mid-seam joint that has precise dimensions for accepting an engineered EPDM gasket. Infiltrator's gasket design utilizes technology from the water industry to deliver proven means of maintaining a watertight seal. The two-piece design is permanently fastened using a series of non-corrosive plastic alignment dowels and locking seam clips. The IM-540 is assembled and sold through a network of certified Infiltrator distributors.

IM-540	
Total Capacity	552 gal (2090 L)
Length	64.9" (1648 mm)
Width	61.7" (1567 mm)
Height	54.6" (1387 mm)
Maximum Burial Depth	48" (1219 mm)
Minimum Burial Depth	6" (152 mm)
Maximum Pipe Diameter	4" (100 mm)
Weight	169 lbs (77 kg)

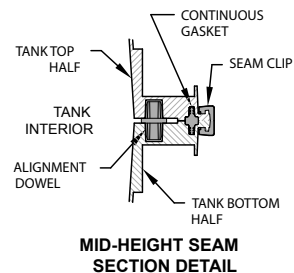
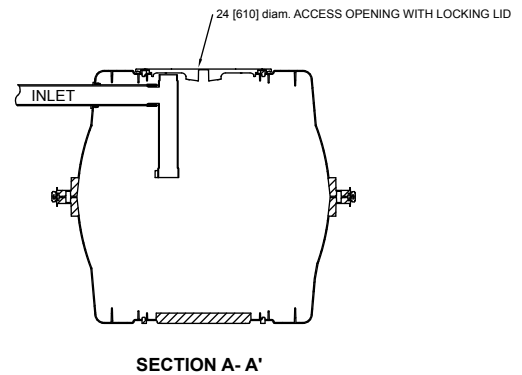
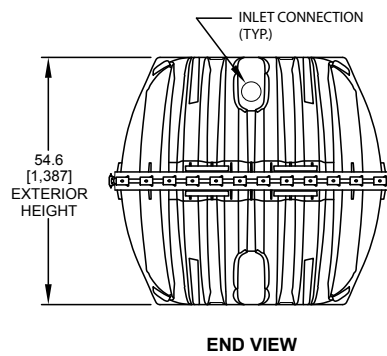
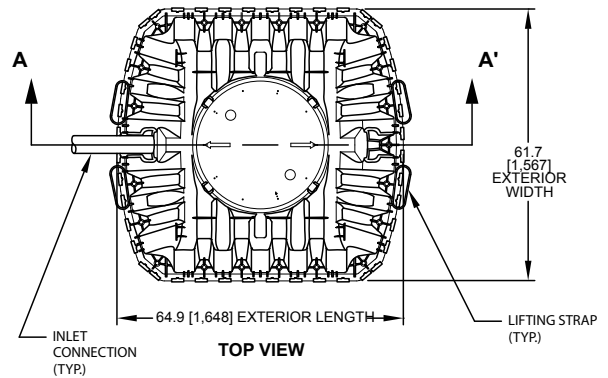

4 Business Park Road  
 P.O. Box 768  
 Old Saybrook, CT 06475  
 860-577-7000 • Fax 860-577-7001  
**1-800-221-4436**  
[www.infiltratorwater.com](http://www.infiltratorwater.com)

U.S. Patents: 4,759,661; 5,017,041; 5,156,488; 5,336,017; 5,401,116; 5,401,459; 5,511,903; 5,716,163; 5,588,778; 5,839,844 Canadian Patents: 1,329,959; 2,004,564 Other patents pending. Infiltrator, Equalizer, Quick4, and SideWinder are registered trademarks of Infiltrator Water Technologies. Infiltrator is a registered trademark in France. Infiltrator Water Technologies is a registered trademark in Mexico. Contour, MicroLeaching, PolyTuff, ChamberSpacer, MultiPort, PosiLock, QuickCut, QuickPlay, SnapLock and StraightLock are trademarks of Infiltrator Water Technologies. PolyLok is a trademark of PolyLok, Inc. TUF-TITE is a registered trademark of TUF-TITE, INC. Ultra-Rib is a trademark of IPEX Inc.

© 2013 Infiltrator Water Technologies, LLC. All rights reserved. Printed in U.S.A.

IM11 0813

**Contact Infiltrator Water Technologies' Technical Services Department for assistance at 1-800-221-4436**



Reinforced watertight mid-seam gasketed connection

■ **Lightweight strong and durable septic/pump tank, making it optimal for use in-series with other tanks**

This watertight tank design is offered with Infiltrator's line of custom-fit risers and heavy-duty lids. Infiltrator injection molded tanks provide a revolutionary improvement in plastic tank design, offering long-term exceptional strength and watertightness.

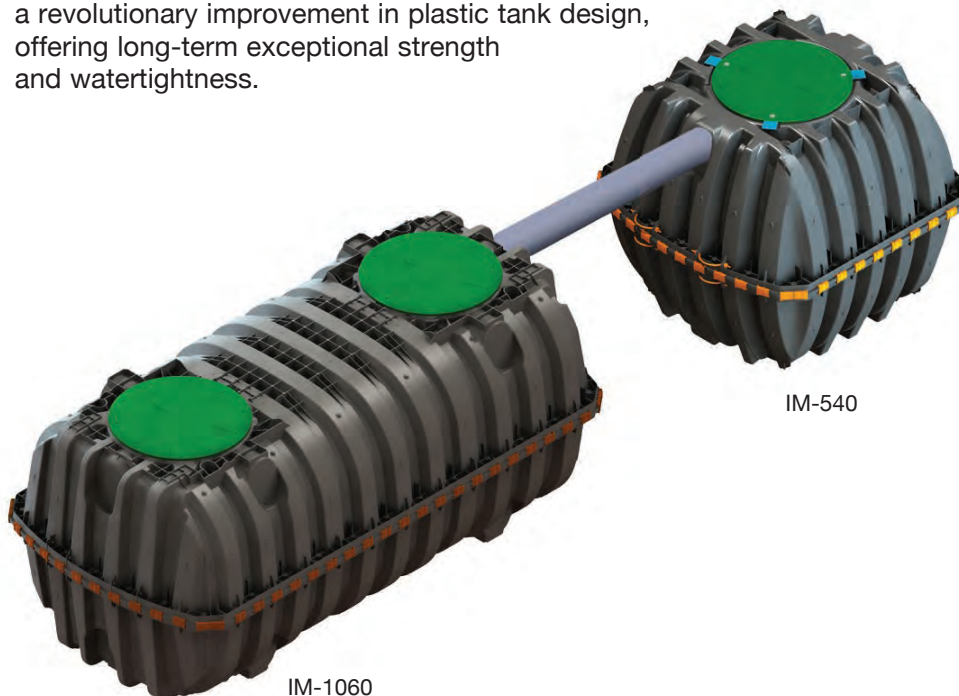

IM-1060

IM-540

### Applications

**Retrofit:** The IM-540 can increase the volume of an existing septic tank.

**New:** Use the IM-540 in new in-series installations with another tank.

**Trash/Pump-Tank:** Ideally-sized for use as a trash-tank or pump tank.

### Features & Benefits

- Strong injection molded polypropylene construction
- Lightweight plastic construction and inboard lifting lugs allow for easy delivery and handling
- Integral heavy-duty green lids that interconnect with TW™ risers and pipe riser solutions
- Structurally reinforced access ports eliminate distortion during installation and pump-outs
- Reinforced structural ribbing offers additional strength
- Can be installed with 6" to 48" of cover
- Can be pumped dry during pump-outs
- No special installation, backfill or water filling procedures are required

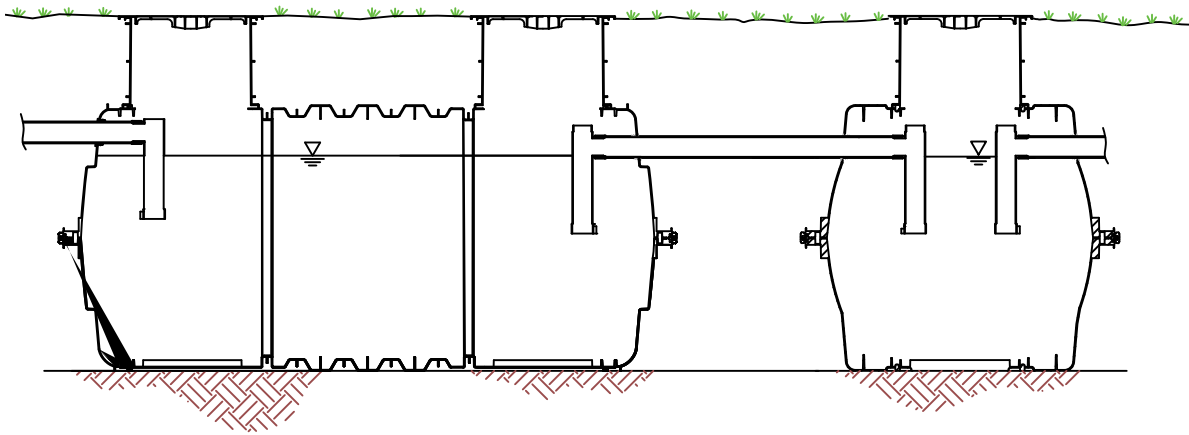

The IM-540 is an injection molded two piece mid-seam plastic tank. The injection molded plastic design allows for a mid-seam joint that has precise dimensions for accepting an engineered EPDM gasket. Infiltrator's gasket design utilizes technology from the water industry to deliver proven means of maintaining a watertight seal. The two-piece design is permanently fastened using a series of non-corrosive plastic alignment dowels and locking seam clips. The IM-540 is assembled and sold through a network of certified Infiltrator distributors.

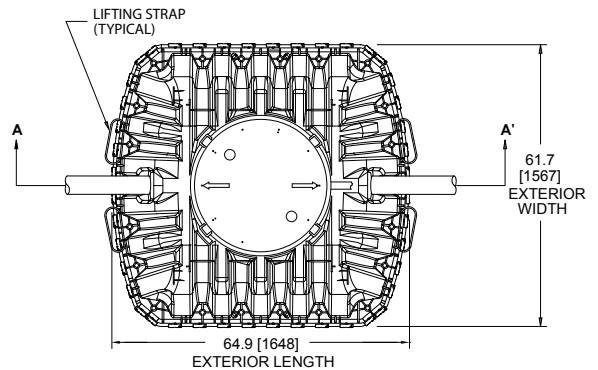

TOP VIEW

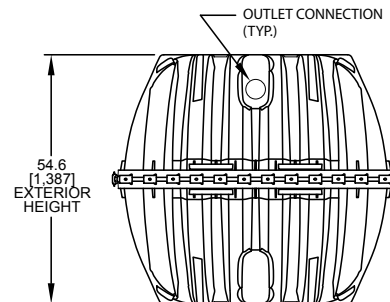

END VIEW

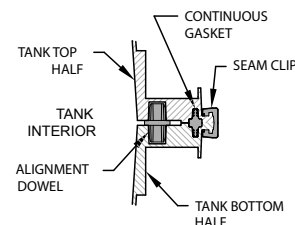

MID-HEIGHT SEAM SECTION DETAIL

**IM-540**

Working Capacity	475 gal (1799 L)
Total Capacity	552 gal (2089 L)
Airspace	16.2%
Length	64.9" (1648 mm)
Width	61.7" (1567 mm)
Height	54.6" (1387 mm)
Liquid Level	44" (1118 mm)
Compartments	1
Maximum Burial Depth	48" (1219 mm)
Minimum Burial Depth	6" (152 mm)
Maximum Pipe Diameter	4" (100 mm)
Weight	169 lbs (77 kg)



**INFILTRATOR**  
water technologies

4 Business Park Road  
P.O. Box 768  
Old Saybrook, CT 06475  
860-577-7000 • Fax 860-577-7001  
**1-800-221-4436**  
[www.infiltratorwater.com](http://www.infiltratorwater.com)

U.S. Patents: 4,759,661; 5,017,041; 5,156,488; 5,336,017; 5,401,116; 5,401,459; 5,511,903; 5,716,163; 5,588,778; 5,839,844 Canadian Patents: 1,329,959; 2,004,564 Other patents pending. Infiltrator, Equalizer, Quick4, and SideWinder are registered trademarks of Infiltrator Water Technologies. Infiltrator is a registered trademark in France. Infiltrator Water Technologies is a registered trademark in Mexico. Contour, MicroLeaching, PolyTuff, ChamberSpacer, MultiPort, PosiLock, QuickCut, QuickPlay, SnapLock and StraightLock are trademarks of Infiltrator Water Technologies. PolyLok is a trademark of PolyLok, Inc. TUF-TITE is a registered trademark of TUF-TITE, INC. Ultra-Rib is a trademark of IPEX Inc.

© 2013 Infiltrator Water Technologies, LLC. All rights reserved. Printed in U.S.A.

IM19 0813

**Contact Infiltrator Water Technologies' Technical Services Department for assistance at 1-800-221-4436**



## Features & Benefits

- Strong injection molded polypropylene construction
- Lightweight plastic construction and inboard lifting lugs allow for easy delivery and handling
- Integral heavy-duty green lids that interconnect with TW™ risers and pipe riser solutions
- Structurally reinforced access ports eliminate distortion during installation and pump-outs
- Reinforced structural ribbing and fiberglass bulkheads offer additional strength
- Can be installed with 6" to 48" of cover
- Can be pumped dry during pump-outs
- Suitable for use as a septic tank, pump tank, or rainwater (non-potable) tank
- No special installation, backfill or water filling procedures are required

The Infiltrator IM-1060 is a lightweight strong and durable septic tank. This watertight tank design is offered with Infiltrator's line of custom-fit risers and heavy-duty lids. Infiltrator injection molded tanks provide a revolutionary improvement in plastic septic tank design, offering long-term exceptional strength and watertightness.

### TANK CUTAWAY

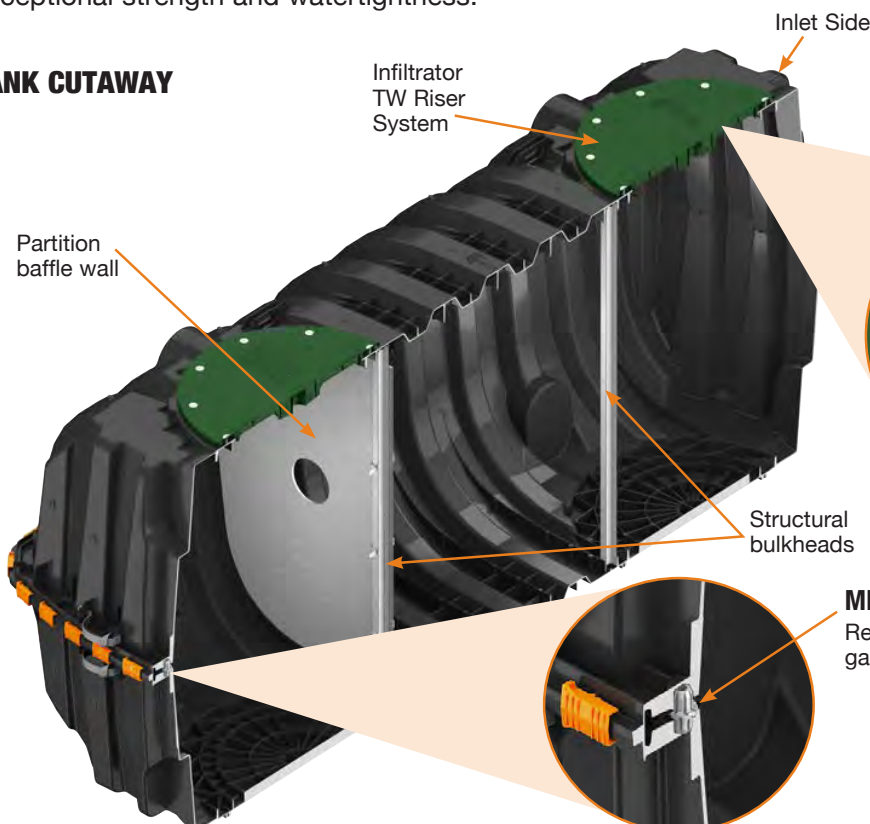

### HEAVY DUTY LID CUTAWAY

Reinforced 24" structural access port

### MID-SEAM CUTAWAY

Reinforced water tight mid-seam gasketed connection

# IM-1060 General Specifications and Illustrations

The IM-1060 is an injection molded two piece mid-seam plastic tank. The IM-1060 injection molded plastic design allows for a mid-seam joint that has precise dimensions for accepting an engineered EPDM gasket. Infiltrator's gasket design utilizes technology from the water industry to deliver proven means of maintaining a watertight seal. The two-piece design is permanently fastened using a series of non-corrosive plastic alignment dowels and locking seam clips. The IM-1060 is assembled and sold through a network of certified Infiltrator distributors.

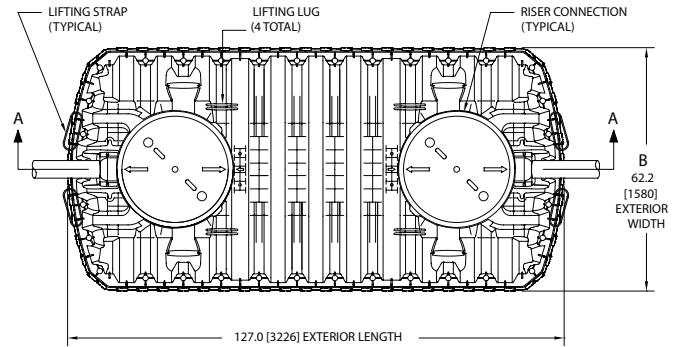

**TOP VIEW**

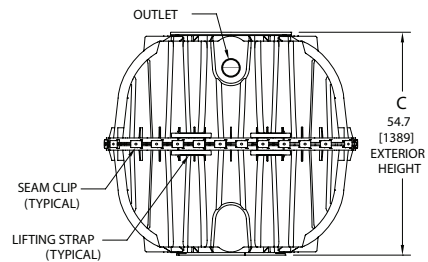

**END VIEW**

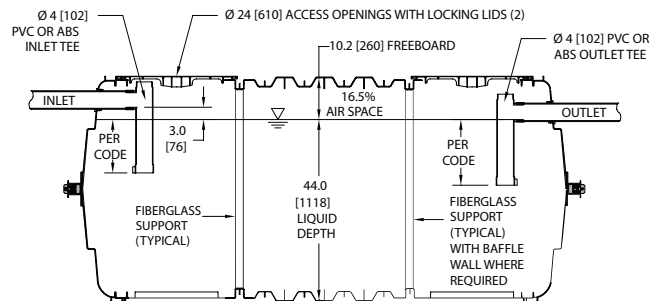

**SIDE VIEW**

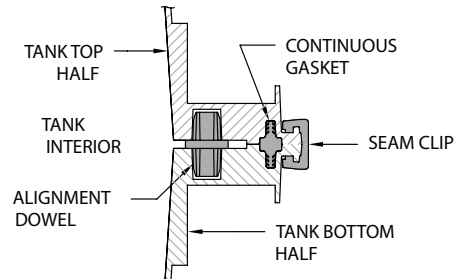

**MID-HEIGHT SEAM SECTION**

IM-1060	
Working Capacity	1094 gal (4141 L)
Total Capacity	1287 gal (4872 L)
Airspace	16.5%
Length	127" (3226 mm)
Width	62.2" (1580 mm)
Length-to-Width Ratio	2.3 to 1
Height	54.7" (1389 mm)
Liquid Level	44" (1118 mm)
Invert Drop	3" (76 mm)
Fiberglass Supports	2
Compartments	1 or 2
Maximum Burial Depth	48" (1219 mm)
Minimum Burial Depth	6" (152 mm)
Maximum Pipe Diameter	6" (152 mm)
Weight	320 lbs (145 kg)



**INFILTRATOR**  
water technologies

4 Business Park Road  
P.O. Box 768  
Old Saybrook, CT 06475  
860-577-7000 • Fax 860-577-7001  
**1-800-221-4436**  
www.infiltratorwater.com

U.S. Patents: 4,759,661; 5,017,041; 5,156,488; 5,336,017; 5,401,116; 5,401,459; 5,511,903; 5,716,163; 5,588,778; 5,839,844 Canadian Patents: 1,329,959; 2,004,564 Other patents pending. Infiltrator, Equalizer, Quick4, and SideWinder are registered trademarks of Infiltrator Water Technologies. Infiltrator is a registered trademark in France. Infiltrator Water Technologies is a registered trademark in Mexico. Contour, MicroLeaching, PolyTuff, ChamberSpacer, MultiPort, PosiLock, QuickCut, QuickPlay, SnapLock and StraightLock are trademarks of Infiltrator Water Technologies. PolyLok is a trademark of PolyLok, Inc. TUF-TITE is a registered trademark of TUF-TITE, INC. Ultra-Rib is a trademark of IPEX Inc.

© 2013 Infiltrator Water Technologies, LLC. All rights reserved. Printed in U.S.A.

IM02 1213

**Contact Infiltrator Water Technologies' Technical Services Department for assistance at 1-800-221-4436**

The Infiltrator IM-1530 is a lightweight strong and durable septic tank. This watertight tank design is offered with Infiltrator's line of custom-fit risers and heavy-duty lids. Infiltrator injection molded tanks provide a revolutionary improvement in plastic septic tank design, offering long-term exceptional strength and watertightness.

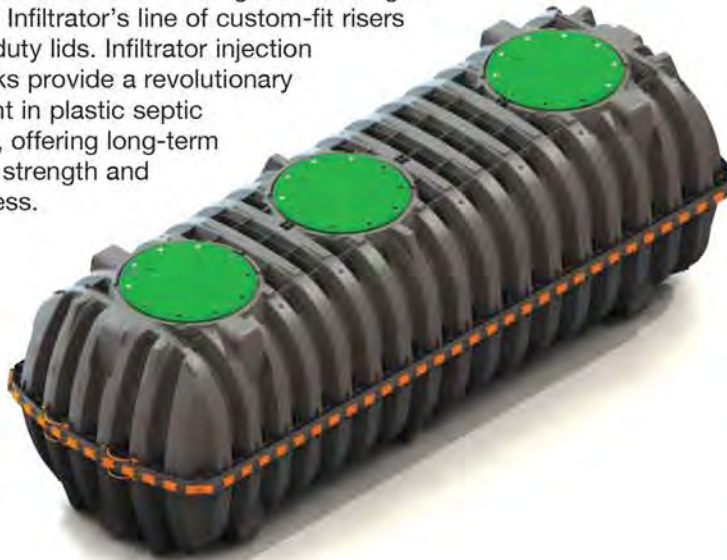

## Features & Benefits

- Strong injection molded polypropylene construction
- Lightweight plastic construction and inboard lifting lugs allow for easy delivery and handling
- Integral heavy-duty green lids that interconnect with TW™ risers and pipe riser solutions
- Structurally reinforced access ports eliminate distortion during installation and pump-outs
- Reinforced structural ribbing and fiberglass bulkheads offer additional strength
- Can be installed with 6" to 48" of cover
- Can be pumped dry during pump-outs
- Suitable for use as a septic tank, pump tank, or rainwater (non-potable) tank
- No special installation, backfill or water filling procedures are required

### TANK CUTAWAY

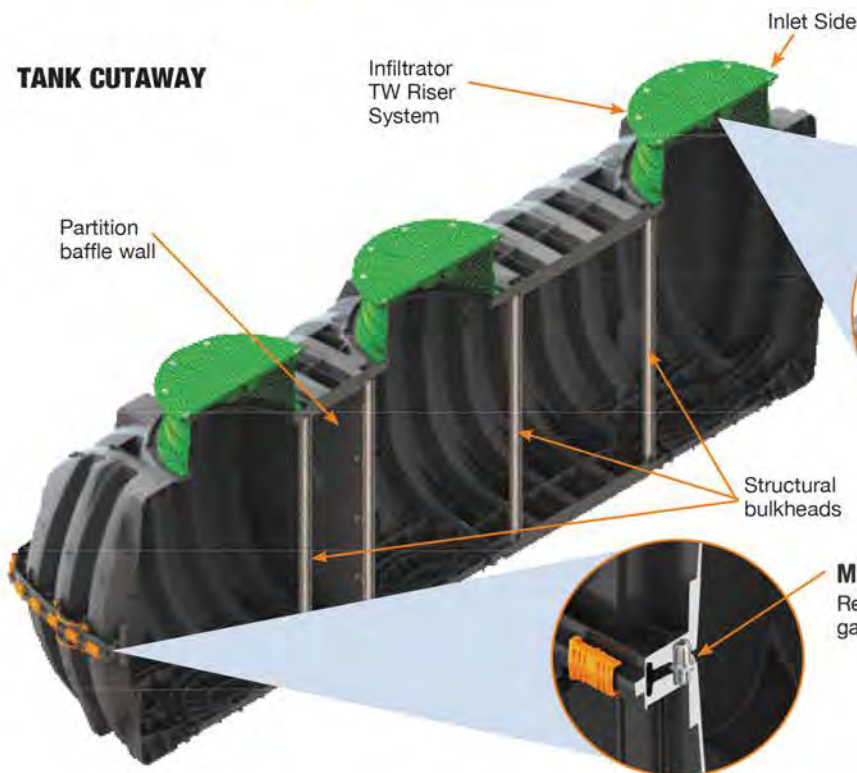

### HEAVY DUTY LID CUTAWAY

Reinforced 24" structural access port

### MID-SEAM CUTAWAY

Reinforced water tight mid-seam gasketed connection

# IM-1530 General Specifications and Illustrations

The IM-1530 is an injection molded two piece mid-seam plastic tank. The IM-1530 injection molded plastic design allows for a mid-seam joint that has precise dimensions for accepting an engineered EPDM gasket. Infiltrator's gasket design utilizes technology from the water industry to deliver proven means of maintaining a watertight seal.

The two-piece design is permanently fastened using a series of non-corrosive plastic alignment dowels and locking seam clips. The IM-1530 is assembled and sold through a network of certified Infiltrator distributors.

IM-1530	
Working Capacity	1537 gal (5818 L)
Total Capacity	1787 gal (6765 L)
Airspace	16.9%
Length	176" (4460 mm)
Width	62" (1567 mm)
Length-to-Width Ratio	2.8 to 1
Height	55" (1384 mm)
Liquid Level	44" (1118 mm)
Invert Drop	3" (76 mm)
Fiberglass Supports	4
Compartments	1 or 2
Maximum Burial Depth	48" (1219 mm)
Minimum Burial Depth	6" (152 mm)
Maximum Pipe Diameter	4" (100 mm)
Weight	501 lbs (228 kg)

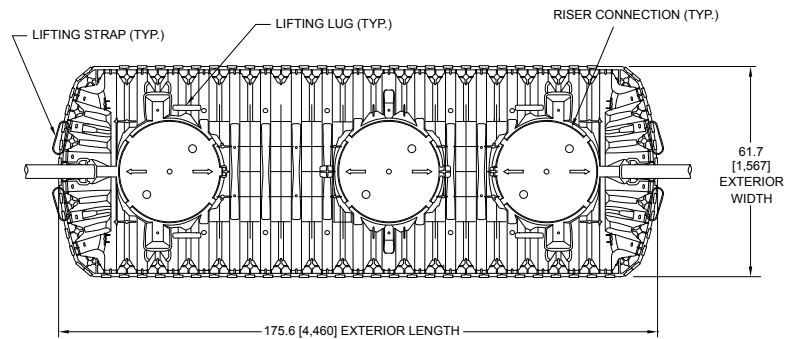

TOP VIEW

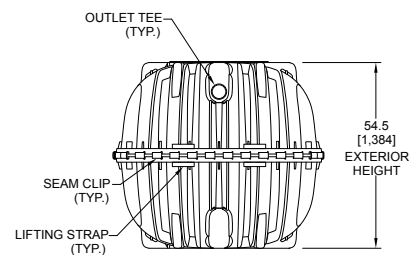

END VIEW

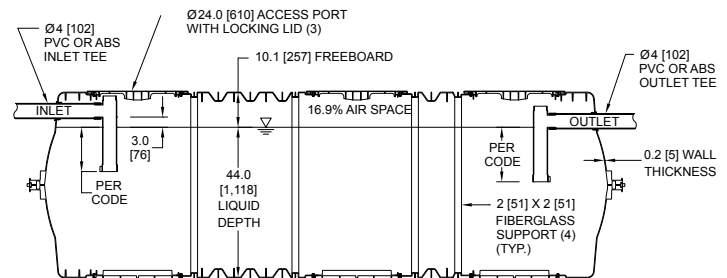

SIDE VIEW

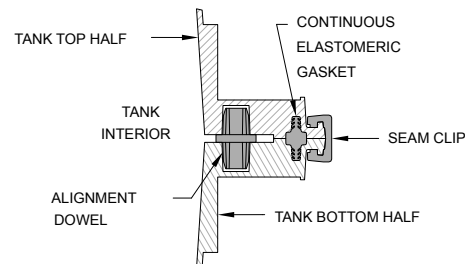

MID-HEIGHT SEAM SECTION



4 Business Park Road  
P.O. Box 768  
Old Saybrook, CT 06475  
860-577-7000 • Fax 860-577-7001  
**1-800-221-4436**  
[www.infiltratorwater.com](http://www.infiltratorwater.com)

U.S. Patents: 4,759,661; 5,017,041; 5,156,488; 5,336,017; 5,401,116; 5,401,459; 5,511,903; 5,716,163; 5,588,778; 5,839,844 Canadian Patents: 1,329,959; 2,004,564 Other patents pending. Infiltrator, Equalizer, Quick4, and SideWinder are registered trademarks of Infiltrator Water Technologies. Infiltrator is a registered trademark in France. Infiltrator Water Technologies is a registered trademark in Mexico. Contour, MicroLeaching, PolyTuff, ChamberSpacer, MultiPort, PosiLock, QuickCut, QuickPlay, SnapLock and StraightLock are trademarks of Infiltrator Water Technologies. PolyLok is a trademark of PolyLok, Inc. TUF-TITE is a registered trademark of TUF-TITE, INC. Ultra-Rib is a trademark of IPEX Inc.

© 2014 Infiltrator Water Technologies, LLC. All rights reserved. Printed in U.S.A.

IM21 0214

Contact Infiltrator Water Technologies' Technical Services Department for assistance at 1-800-221-4436