

2250 GALLON 2 COMP. TANK
1/2" = 1'-0"

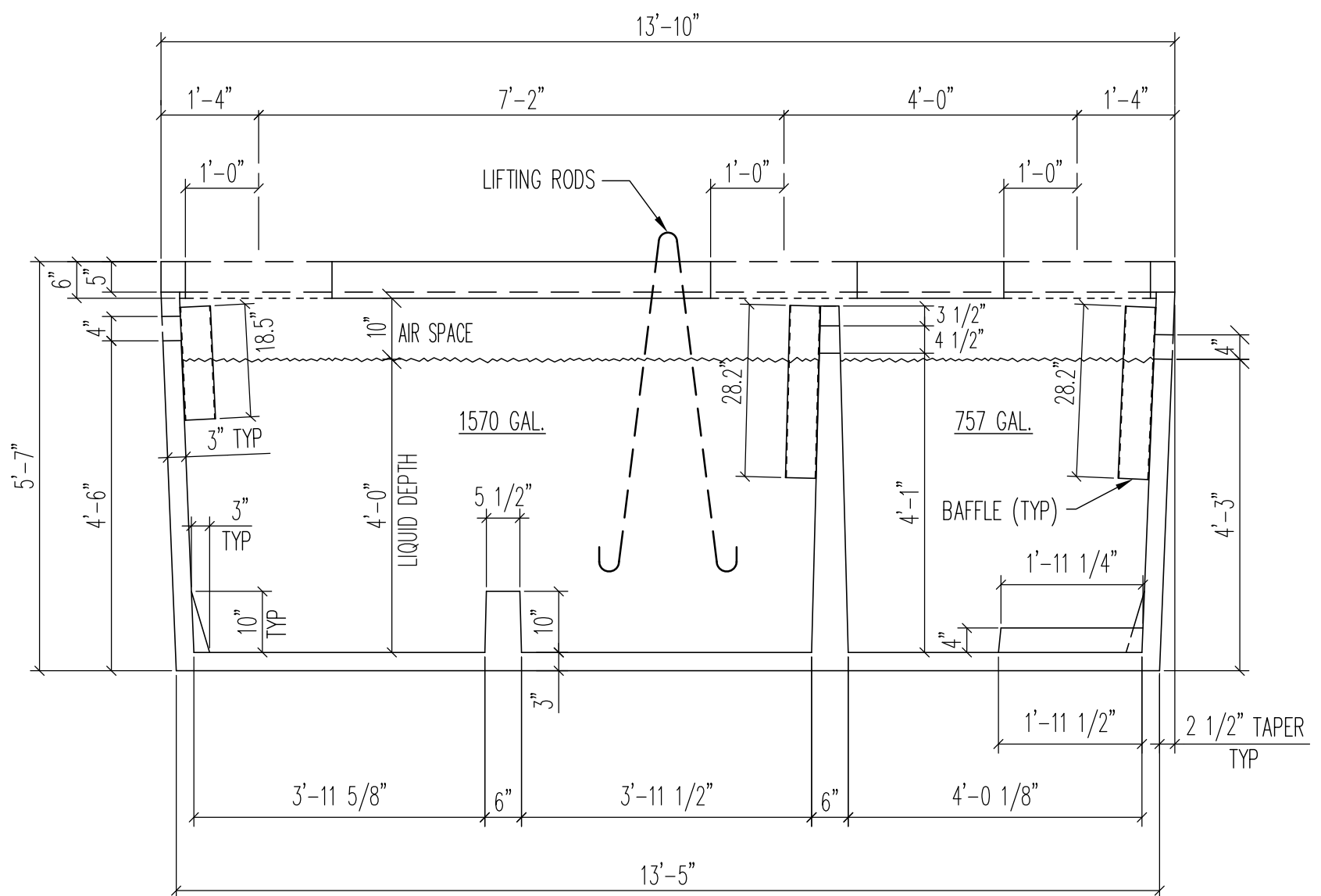

SECTION
1/2" = 1'-0"

NOTE:

1. PROVIDE MINIMUM 1" CLEAR BETWEEN TOP OF BAFFLE AND UNDERSIDE OF LID.

2250 GALLON 2 COMP.
SEPTIC TANK
(2250 2C)

Brown Wilbert

WEIGHT= 20,380#
MAX. SOIL COVER= 8'-0"
TOTAL LIQUID VOLUME= 2327 GAL.

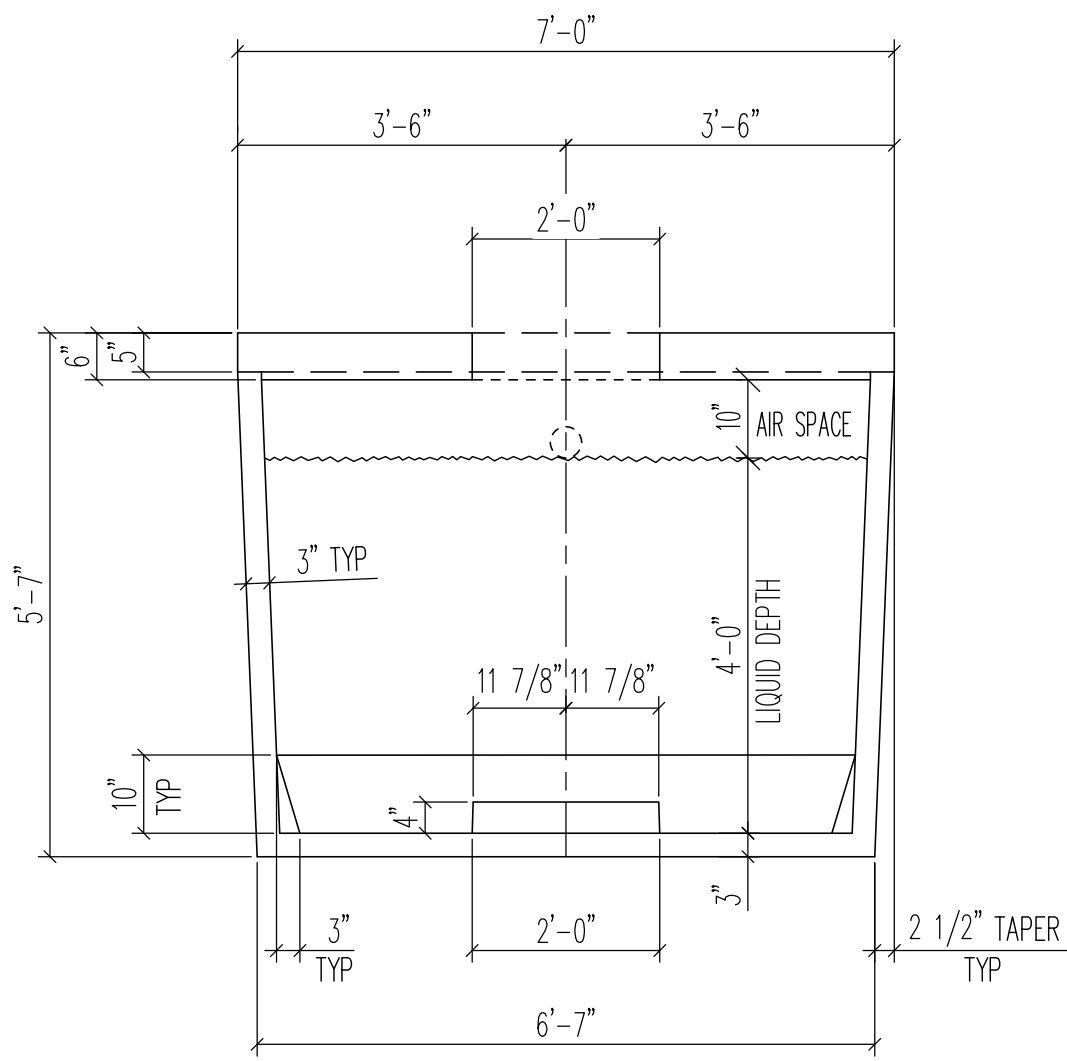

SECTION
 1/2" = 1'-0"

NOTE:
 1. PROVIDE MINIMUM 1" CLEAR BETWEEN TOP OF BAFFLE AND UNDERSIDE OF LID.

2250 GALLON 2 COMP.
 SEPTIC TANK
 (2250 2C)



WEIGHT= 20,380#
 MAX. SOIL COVER= 8'-0"
 TOTAL LIQUID VOLUME= 2327 GAL.